



www.FGWilson.com

# P26-1S



Image for illustration purposes only.

## Output Ratings

Generating Set Model	Prime*	Standby*
220-240V, 50 Hz	24.0 kVA / 24.0 kW	26.0 kVA / 26.0 kW
	- / -	- / -

Ratings at 1.0 power factor.

## Prime Rating

These ratings are applicable for supplying continuous electrical power (at variable load) in lieu of commercially purchased power. There is no limitation to the annual hours of operation and this model can supply 10% overload power for 1 hour in 12 hours.

## Standby Rating

These ratings are applicable for supplying continuous electrical power (at variable load) in the event of a utility power failure. No overload is permitted on these ratings. The alternator on this model is peak continuous rated (as defined in ISO 8528-3).

## Standard Reference Conditions

Note: Standard reference conditions 25°C (77°F) Air Inlet Temp, 100m (328 ft) A.S.L. 30% relative humidity.  
Fuel consumption data at full load with diesel fuel with specific gravity of 0.85 and conforming to BS2869: 1998, Class A2.

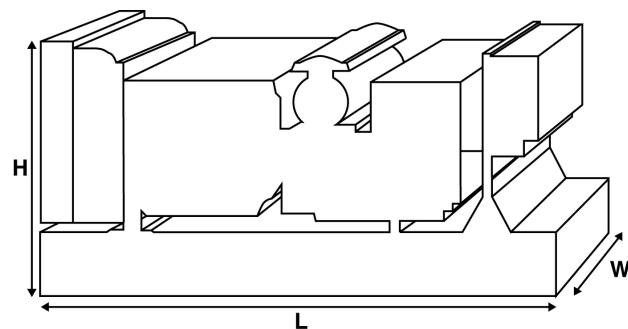

## 3Tech Corporate Limited

Unit 904, 9/F., Fu Hang Industrial Building,

1 Hok Yuen Street East, Hung Hom,  
Kowloon, Hong Kong.

Tel: +852-2766 9787 Fax: +852-2766 9774

Email:sales@3tech.net

Headquarters: Hong Kong China: Beijing, Dongguan, Shenzhen, Xiamen  
Overseas: Nigeria, D.R.Congo, Ghana, Kenya, Tanzania, Pakistan, USA, Canada, France

## Ratings and Performance Data

Engine Make & Model:	Perkins 1103A-33G1	
Alternator manufactured for FG Wilson by:	Leroy Somer	
Alternator Model:	LLB1014S	
Control Panel:	1002T	
Base Frame:	Fbc2 - (08Hr)	
Circuit Breaker Type:	3 Pole MCCB	
Frequency:	50 Hz	60 Hz
Engine Speed: RPM	1500	-
Fuel Tank Capacity: litres (US gal)	161 (42.5)	
Fuel Consumption: l/hr (US gal/hr) (100% Load)	Prime	6.9 (1.8)
	Standby	7.5 (2.0)

## Available Options

- CE Certification
- Sound Attenuated EC Enclosures
- Control Panel Upgrades
- Range of Silencers
- Range of Remote Fuel Systems
- Range of Alarms and Shutdowns

## Dimensions and Weights

Length (L) mm (in)	Width (W) mm (in)	Height (H) mm (in)	Dry kg (lb)	Wet kg (lb)
1540 (60.6)	970 (38.2)	1361 (53.6)	827 (1823)	840 (1852)

Dry = With Lube Oil

Wet = With Lube Oil and Coolant

Ratings in accordance with ISO 8528, ISO 3046, IEC 60034, BS5000 and NEMA MG-1/22.  
Generating set pictured may include optional accessories.



## Engine Technical Data

<b>No. of Cylinders / Alignment:</b>	3 / In Line		
<b>Cycle:</b>	4 Stroke		
<b>Bore / Stroke: mm (in)</b>	105.0 (4.1)/127.0 (5.0)		
<b>Induction:</b>	Naturally Aspirated		
<b>Cooling Method:</b>	Water		
<b>Governing Type:</b>	Mechanical		
<b>Governing Class:</b>	ISO 8528 G2		
<b>Compression Ratio:</b>	19.25:1		
<b>Displacement: l (cu. in)</b>	3.3 (201.4)		
<b>Moment of Inertia: kg m<sup>2</sup> (lb/in<sup>2</sup>)</b>	1.14 (3896)		
<b>Engine Electrical System:</b>			
- Voltage / Ground	12/Negative		
- Battery Charger Amps	65		
<b>Weight: kg (lb)</b>	- Dry	412 (908)	
	- Wet	430 (948)	

## Performance

	50 Hz	60 Hz
<b>Engine Speed: rpm</b>	1500	-
<b>Gross Engine Power: kW (hp)</b>		
- Prime	28.2 (38.0)	-
- Standby	31.0 (42.0)	-
<b>BMEP: kPa (psi)</b>		
- Prime	684.0 (99.2)	-
- Standby	752.0 (109.0)	-

## Fuel System

<b>Fuel Filter Type:</b>	Replaceable Element			
<b>Recommended Fuel:</b>	Class A2 Diesel			
<b>Fuel Consumption: l/hr (US gal/hr)</b>				
	110%	100%	75%	50%
<b>Prime</b>	<b>Load</b>	<b>Load</b>	<b>Load</b>	<b>Load</b>
50 Hz	7.5 (2.0)	6.9 (1.8)	5.2 (1.4)	3.8 (1.0)
60 Hz	-	-	-	-
	110%	100%	75%	50%
<b>Standby</b>	<b>Load</b>	<b>Load</b>	<b>Load</b>	<b>Load</b>
50 Hz	7.5 (2.0)	5.6 (1.5)	4.0 (1.1)	
60 Hz	-	-	-	

(Based on diesel fuel with a specific gravity of 0.84 and conforming to BS2869, Class A2)

## Air Systems

	50 Hz	60 Hz
<b>Air Filter Type:</b>	Replaceable Element	
<b>Combustion Air Flow: m<sup>3</sup>/min (cfm)</b>		
- Prime	2.2 (76)	-
- Standby	2.2 (76)	-
<b>Max. Combustion Air Intake Restriction: kPa (in H<sub>2</sub>O)</b>	6.5 (26.1)	-

## Cooling System

	50 Hz	60 Hz
<b>Cooling System Capacity: l (US gal)</b>	10.2 (2.7)	-
<b>Water Pump Type:</b>	Centrifugal	
<b>Heat Rejected to Water &amp; Lube Oil:</b>		
kW (Btu/min)	- Prime	16.0 (910)
	- Standby	18.0 (1024)
<b>Heat Radiation to Room: Heat radiated from engine and alternator</b>		
kW (Btu/min)	- Prime	5.0 (284)
	- Standby	6.0 (341)
<b>Radiator Fan Load: kW (hp)</b>	0.3 (0.4)	-
<b>Radiator Cooling Airflow: m<sup>3</sup>/min (cfm)</b>	62.6 (2211)	-
<b>External Restriction to Cooling Airflow: Pa (in H<sub>2</sub>O)</b>	125 (0.5)	-

Cooling system designed to operate in ambient conditions up to 50°C (122°F). Contact your local FG Wilson Dealer for power ratings at specific site conditions.

## Lubrication System

<b>Oil Filter Type:</b>	Spin-On, Full Flow	
<b>Total Oil Capacity: l (US gal)</b>	8.3 (2.2)	
<b>Oil Pan: l (US gal)</b>	7.8 (2.1)	
<b>Oil Type:</b>	API CG4 / CH4 15W-40	
<b>Oil Cooling Method:</b>	Water	

## Exhaust System

	50 Hz	60 Hz
<b>Silencer Type:</b>	Industrial	
<b>Silencer Model &amp; Quantity:</b>	SD50 (1)	
<b>Pressure Drop Across Silencer System: kPa (in Hg)</b>		
	1.80 (0.532)	-
<b>Silencer Noise Reduction Level: dB</b>	20	-
<b>Maximum Allowable Back Pressure: kPa (in Hg)</b>		
	8.0 (2.4)	-
<b>Exhaust Gas Flow: m<sup>3</sup>/min (cfm)</b>		
- Prime	6.0 (212)	-
- Standby	6.0 (212)	-
<b>Exhaust Gas Temperature: °C (°F)</b>		
- Prime	500 (932)	-
- Standby	512 (954)	-



**Documentation**

A full set of operation and maintenance manuals and circuit wiring diagrams.

**Generating Set Standards**

The equipment meets the following standards: BS5000, ISO 8528, ISO 3046, IEC 60034, NEMA MG-1.22.

FG Wilson is a fully accredited ISO 9001 company.

**Warranty**

All prime equipment carries a one year manufacturer's warranty. Standby equipment, limited to 500 running hours per year, has a two year manufacturer's warranty. For details on warranty cover please contact your local Dealer, or visit our website: [FGWilson.com](http://FGWilson.com).

**Dealer contact details:**